

RMTTree Consultancy Ltd

36 Chetwode Place, Aldershot, Hants, GU12 4BS – Email: rmttreeconsultancy@gmail.com
Tel: 07921 313967



BS5837:2012 Arboricultural Survey Impact Assessment & Arboricultural Method Statement

**Site Address:
Horley Town Council Offices
92 Albert Road
Horley
RH6 7HZ**

**Robert Toll
HND Urban Forestry - ND Forestry - MArborA
Ref: RMT1065
Site inspection date: 5th December 2024
Date report published: 16th December 2024
Prepared for Horley Town Council**



PRO2239

Contents

Ref no.	Title	Page no.
	Title Page	
	Contact and Report Details	
	Contents	
1	Instruction	1
2	Introduction	1
	- Site description	1
	- Limitations	2
	- Legal restrictions	2
	- Tree survey	2
	- Canopy spreads	3
	- Root protection areas	3
3	Soil Assessment	4
4	Arboricultural Impact Assessment	5
	- Arboricultural impact assessment overview	5
	- Access facilitation pruning	5
	- Tree protection fencing	5
	- Ground protection	5
	- Constructing hard surfacing close to trees	6
	- Areas for site compounds, storage and mixing	7
	- Services	7
	- Conclusions	8
5	Arboricultural Method Statement	9
	- Access facilitation works	9
	- Pre-commencement meeting	9
	- Protective barriers/fencing	9
	- Warning signs	10
	- Temporary ground protection within RPAs	11
	- Method of constructing no dig surfaces close to trees	12

Appendices

Appendix 1 – British Standard 5837:2012 tree categorisation chart	14
Appendix 2 – Tree survey schedule	15
Appendix 3 – Tree Constraints Plan – RMT1065 – TCP	17
Appendix 4 – Tree Protection Plan – RMT1065 – TPP	18
Appendix 5 – Arboricultural site supervision schedule	19
Appendix 6 – Site monitoring form	20
Appendix 7 – Cellweb installation guide	21
Appendix 8 – Qualifications and experience	24

1 Instructions

- 1.1 On the 29th November 2024 I was instructed on behalf of Horley Town Council by the Assistant Town Clerk & Responsible Finance Officer, Sam Adeniji, to undertake a survey of trees that are on or adjacent to Horley Town Council Offices, 92 Albert Road, Horley, RH6 7HZ in accordance with *British Standard 5837:2012 Trees in relation to design, demolition and construction – Recommendations*.
- 1.2 I am a qualified arboriculturalist as it is detailed at **Appendix 8** and this report has been produced in support of a planning application to Reigate and Banstead Borough Council for construction of a single storey rear extension with works to upgrade existing building and facilities for both staff and external users hiring the main hall, revised vehicle and cycle parking arrangements, introduction of photovoltaics and fenestration changes.

2 Introduction

Site Description

- 2.1 The site consists of the council offices located in the western half of the site and the car park and grassed grounds in the eastern half. The site is accessed via an asphalt access from the south-western corner of the site and it is routed to the main car park is adjacent to the eastern corner of the Council Offices.

Image 1 – Horley Town Council Offices, 92 Albert Road, Horley, RH6 7HZ shown by an indicative red line



Limitations

- 2.2 I carried out the survey from ground level with the aid of a Bosch GLM 120 C Professional Laser Measure to measure distances, a Nikon Forestry Pro height measurer and diameter tape.
- 2.3 Prior to visiting the property I was not supplied with a topographical survey.
- 2.4 Trees and groups T1 – T7 have been annotated onto the plans to the best of the arboriculturalist's ability.
- 2.5 All measurements taken to calculate root protection areas and canopy spreads have been measured wherever possible. Where it has not been possible to access certain areas, dimensions have been estimated.
- 2.6 Wherever possible all diameter measurements have been measured using a diameter tape at a height of 1.5m. Where it has not been possible to access the stems at 1.5m above ground level due to such things as dense Ivy, trees are offsite or trees are inaccessible, then an estimated measurement has been taken. All estimated measurements include the word "estimated" or the abbreviation "est" in the tree survey schedule shown at **Appendix 2**.
- 2.7 In some instances the diameter measurement has been taken at a height other than 1.5m due to such things as low fork unions. Where this has occurred, I have detailed this in the tree survey schedule shown at **Appendix 2**.
- 2.8 This report does not constitute a safety survey of the trees included within it. It is advised that if there are concerns regarding the risk posed by trees to persons and property then a tree condition inspection should be commissioned.

Legal Restrictions

- 2.9 I have not contacted the local planning authority (LPA) directly to ascertain whether the trees on or adjacent to the site are protected by Tree Preservation Orders (TPO) or if they are within a Conservation Order.
- 2.10 On the 6th December 2024 I carried out a check on the Reigate and Banstead Borough Council online protected tree maps and they indicate that there is no statutory protection on any of the surveyed trees.
- 2.11 It is an offence under the Wildlife and Countryside Act 1981 and the Rights of Way Act 2000 to disturb nesting birds or roosting/breeding bats. When carrying out tree work care should be taken to avoid disturbance. If necessary, advice should be taken to avoid disturbance. If necessary, advice may need to be sought from a qualified Ecologist.

Tree survey

- 2.12 I visited the site on the 5th December 2024 and surveyed a total of seven trees. The surveyed trees have been categorised in accordance with British Standard 5837:2012 as shown at **Appendix 1** and the tree survey schedule can be seen at **Appendix 2**.

2.13 At the time of my survey one tree was considered to be category B and moderate value. The remaining trees are considered to be category C and low value.

Table 1 – Tree categorisations as BS5837:2012

Category A	Category B	Category C	Category U
-	T5	T1, T2, T3, T4, T6, T7	-

2.14 It was noted that there are other trees that are located on or adjacent to Horley Town Council Offices, 92 Albert Road, Horley, RH6 7HZ but they have not been included within this report. This is because it is deemed that they are:

- far enough from the area proposed for development that they will not be affected;
- they will be adequately protected by the tree protection measures afforded to the surveyed trees;
- they are specimens of limited significance;

Canopy spreads

2.15 The canopy spreads have annotated on the tree constraints plan and tree protection plan at **Appendices 3 and 4**.

Root protection area (RPA) definition

2.16 The RPA is a layout design tool indicating the minimum area around a tree deemed to contain sufficient roots and rooting volume to maintain the tree's viability and where the protection of the roots and soil structure are treated as a priority.

3 Soil Assessment

- 3.1 The soil assessment is necessary to establish whether the soil on the proposal site is shrinkable. Tree roots and those of other vegetation have the potential to extract moisture from shrinkable soils such as clay, making the soil expand and contract as the soil desiccates and re-hydrates. Where new structures are proposed on shrinkable soils and close to trees, foundations will need to be sufficiently deepened or able to withstand to minimise the risk of indirect damage to foundations.
- 3.2 No soil assessments have been provided however a check the British Geological Survey gives the soil type as Weald Clay Formation – Mudstone. This means that the underlying soil is shrinkable and as such foundations will need to be deepened. If further assessments are undertaken that show that there is shrinkable clay, then foundations must be designed in accordance with the guidance within the National House Building Council's Standards Chapter 4.2 Building near trees.

Figure 1 – The British Geological Survey indicates that the soil make up at Horley Town Council Offices, 92 Albert Road, Horley, RH6 7HZ is shrinkable Weald Clay Formation - Mudstone.

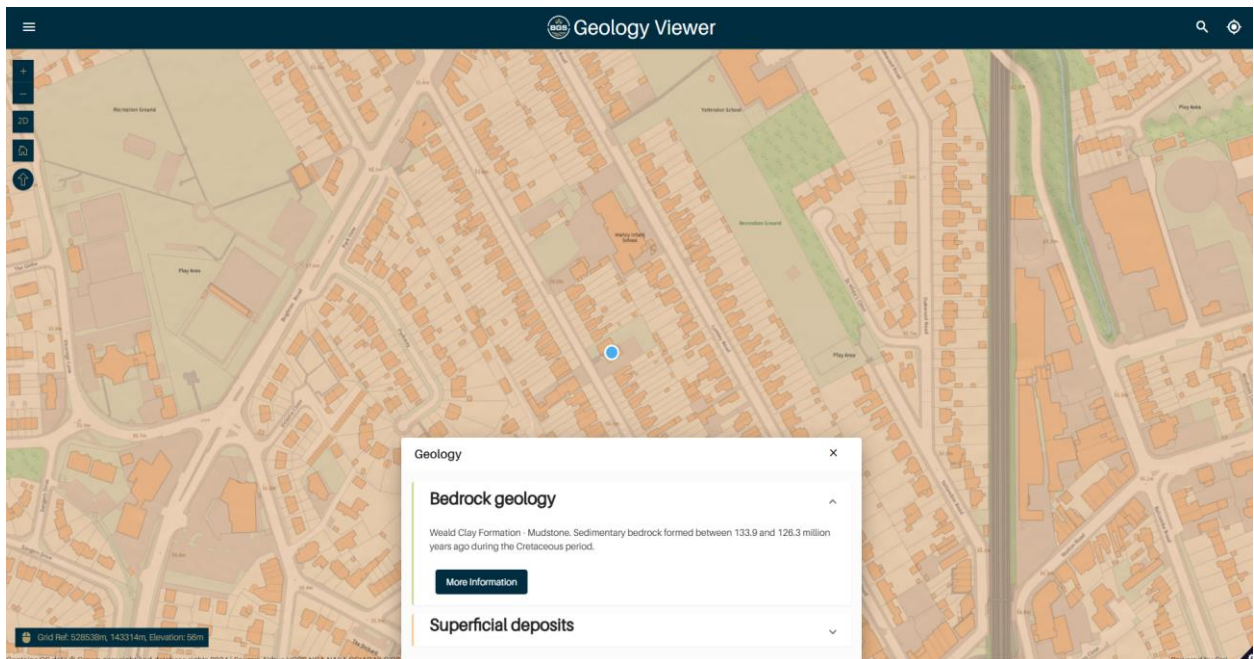

4 Arboricultural Impact Assessment

Arboricultural Impact Assessment overview

- 4.1 The arboricultural impact assessment assesses the direct and indirect effects of the proposed design on trees that are growing or adjacent to the site. Where appropriate mitigation will be recommended to prevent or minimise harm and details mitigation as appropriate. Consideration will be given to the practicality of the design and the viability of tree retention.

Access facilitation pruning

- 4.2 To maintain adequate clearances for construction of the car park it will be necessary to reduce the south-eastern crown spread of tree T2. These works will remove small diameter growth from a small and unremarkable tree. It is considered that these works are reasonable and will not pose a risk to this tree. The specific works are set out at **Appendix 2**.

Tree protection fencing

- 4.3 Tree protection fencing will be required throughout the construction process to restrict construction access within the RPAs of trees T1 – T5. The areas to be protected by the tree protection fencing can be seen as blue lines on the accompanying Tree Protection Plan at **Appendix 4**.
- 4.4 Tree protection fencing will consist of 1.8m high wire mesh panels placed in rubber blocks. The panels will be securely bolted together to prevent movement and a backstay must be attached to each panel to prevent movement and resist impacts. Un-braced weld mesh panels on unsecured rubber or concrete feet will not be used as these are not resistant to impact and are too easily removed by site operatives.
- 4.5 A notice will be attached to the fencing which says 'Tree Protection Area. Keep Out!'.

Ground protection

- 4.6 It has been stated above, the RPA is a sacrosanct area of ground where encroachment by construction activities should be avoided wherever possible. In the case of trees T2 and T5 there will be a requirement for construction access within their RPAs throughout development. Where it is considered that the construction working space or temporary access is justified within their RPAs, this will be facilitated by a set-back in the alignment of the tree protection barrier and suitable ground protection will be installed. Areas to be protected with ground have been shown as orange hatching at **Appendix 4**.
- 4.7 In all cases the objective should be to avoid compaction of the soil, which can arise from the single passage of a heavy vehicle or continual pedestrian movement over the same area, especially in wet conditions. Compaction of the soil can impair root development and function leading to a decline in the physiological and structural condition of the tree.

Constructing hard surfacing close to trees

- 4.8** Where the construction of a surface cannot be avoided within the fenced RPA of retained trees, the soil substrate will form part of the construction profile (sub grade), a 'NO-DIG' approach is to be adopted.
- 4.9** A proposed section of the car park will significantly overlap with the RPA of tree T5. To minimise the impact on the RPA the surface (including any associated edge support) should be engineer designed to take account of site-specific data including soil type, current level if soil type and anticipated axle loads of vehicle using the new surface.
- 4.10** The surface must:
- Provide adequate resistance to applied loads and avoiding localised ground compaction by evenly distributing the carried weight over the track width and wheelbase of any vehicles that will use the access.
 - Provide resistance to or tolerance of deformation by tree roots.
 - Provide oxygen diffusion according to seasonal demand (gas porous).
 - Provide water throughout to meet seasonal demand (permeable).
 - Preserve the soil structure during installation to prevent lack of water, exclusion of oxygen, excessive resistance to penetration (density or soil strength) and or chemical toxicity.
- 4.11** Construction may (where appropriate) incorporate:
- The use of a three-dimensional Cellular Confinement System (CCS), such as Cellweb, as an integral component of the subbase, to act as a suspension layer by creating cells into which recommended material is contained. Here it is necessary to install a geotextile layer between the ground and the cells to prevent mixing and the cellular materials being pressed into the ground.
 - Alternatively, where the use of a CCS is not appropriate due to the underlying soil (and/or other site factors) reinforced concrete slabs, supported and suspended on mini-piles and incorporating a designed system that allows for the passage of water and oxygen to the underlying soil maybe used.
 - Other engineered-designed surfaces that address the requirements of the above performance specification may also be used.
- 4.12** Examples of acceptable hard surface include washed gravel (not binding gravel or hoggin as these are almost impermeable when consolidated); dry jointed paving slabs, pavers or bricks on a sharp sand foundation, permeable paving blocks or pre-made concrete slabs with 50mm diameter holes at regular spacing of 300-600mm (to be agreed) with a no-fines aggregate back filling of the openings.

4.13 Section 7.4.2.3 of British Standard 5837:2012 recommends that proposed new permanent hard standing should not exceed more than 20% of the total unsurfaced ground within RPAs. The table shown as Table 2 provides a break-down of the total overlaps into the RPA of tree T5.

Table 2 – Table showing new surfacing overlap into RPAs of trees

Tree no.	RPA area	Existing surfacing within RPA	Unsurfaced areas within RPA	New overlap into unsurfaced RPA	Percentage of new overlap into unsurfaced RPA
T5	289.5m ²	0m ²	289.5m ²	52.3m ²	18.07%

4.14 On this occasion it has been demonstrated that the total overlap into the unsurfaced RPA of tree T5 does not exceed 20%. As such the new surfacing within the RPA of this tree can be constructed using a no dig cellular confinement system (Cellweb).

Areas for site compounds, storage and mixing

4.15 Site compounds will be located away from trees wherever possible and ideally 2m from any protective barriers.

4.16 On this occasion it is proposed to utilise the area of car park for the site compound, storage and mixing as shown at **Appendix 4**.

Services

4.17 The proposed layout of incoming (water, gas and electricity) and outgoing (foul sewer) services is not yet established but they should be installed outside root protection areas. If it is necessary for a trench to be dug through an RPA a specific method statement will be required which will need to specify that the trench will be hand dug and that care will be taken to preserve all roots encountered which are larger than 25 mm diameter.

4.18 There is considered to be ample space for services to be routed without having to pass through the RPAs of trees.

Conclusions

- 4.19 I visited Horley Town Council Offices, 92 Albert Road, Horley, RH6 7HZ on the 5th December 2024 and surveyed a total of seven trees.
- 4.20 At the time of my survey one tree was considered to be category B and moderate value. The remaining trees are considered to be category C and low value.
- 4.21 All trees were categorised in accordance with British Standard 5837:2012 as shown at **Appendix 1**.
- 4.22 The development will require not require the removal of any trees.
- 4.23 Minor works to reduce the south-eastern crown of category C tree T2 will be required to facilitate development.
- 4.24 A section of the car park will be within the RPA of tree T5 and it has been demonstrated that it can be constructed using a three-dimensional cellular confinement system (Cellweb).
- 4.25 The trees to be retained will be protected during development and methods for ensuring their protection have been described.
- 4.26 The development is sympathetic to the leafy character of the area.

5 Arboricultural Method Statement

Access facilitation works

- 5.1 The agreed pruning works will be carried out as preliminary works as detailed at **Appendix 2**. These works will be carried out by suitably qualified arborists to the standards set out in BS3998: 2010 Tree works – recommendations. Heavy machinery must not be used on unprotected ground.

Pre-commencement meeting

- 5.2 Prior to the commencement of development all tree protection will be erected and a site meeting will be held between the appointed building contractors, the appointed arboriculturalist and local authority Tree Officer as it is stipulated at **Appendix 5**. This meeting is necessary to agree that the position of the tree protection is correct.

Protective barriers/fencing

- 5.3 All tree protection barriers will be erected in the positions shown in **Appendix 4** and in accordance with the specifications detailed in Figures 2 and 3.

Figures 2 and 3 – Examples of above-ground stabilizing systems

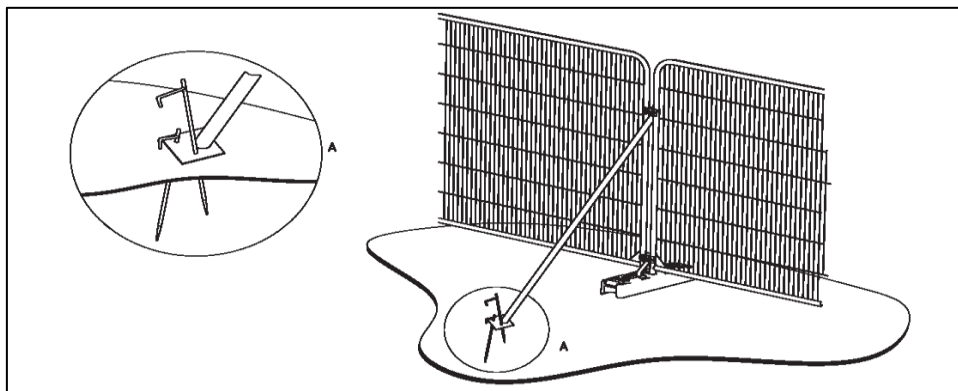

a) Stabilizer strut with base plate secured with ground pins

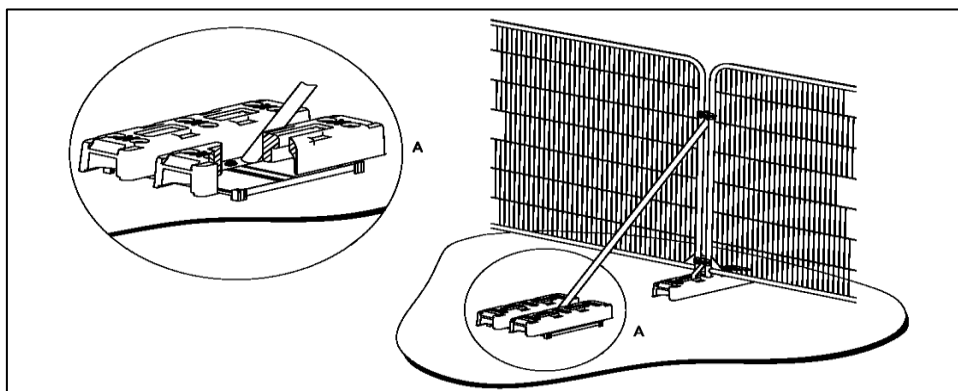

b) Stabilizer strut mounted on block tray

Image taken from British Standard 5837:2012 – Trees in relation to design, demolition and construction – Recommendations.

Warning signs

5.4 All weather notices will be attached to the tree protection fencing.

Figure 4 – Examples of tree protection warning sign.



5.5 All ground protection will be laid as follows:

Specification of temporary ground protection within RPAs

5.6 A permeable geotextile such as Terram will be laid and onto this will be placed treated timber (100 mm x 80 mm) at spacings of no more than 1m. The area between the timber bearers will be filled with a compressible material such as woodchips and will then be covered by 20 mm thick marine ply which will be screwed down onto the timber (Figures 5 and 6). The plywood may need to be coated with a non-slip paint.

Figure 5 – Specification for ply board ground protection

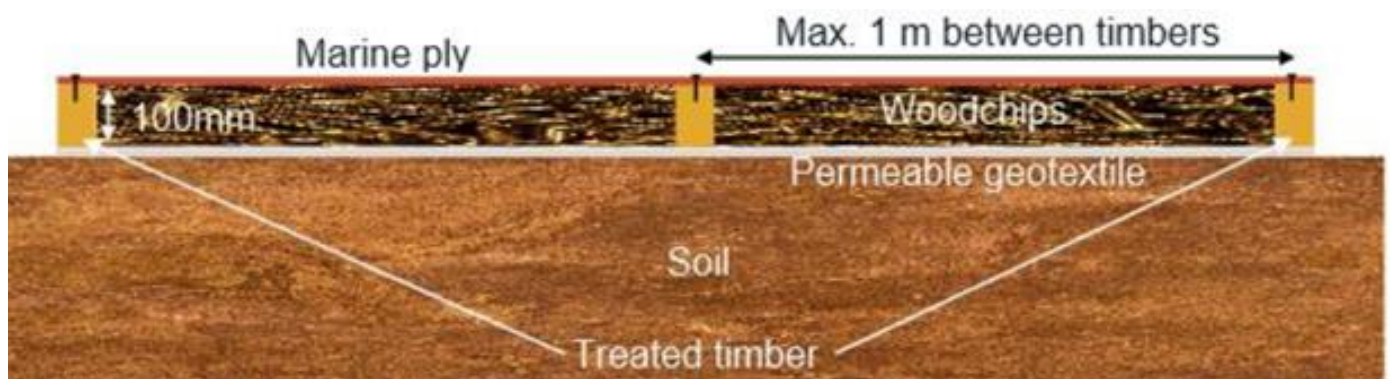

Figure 6 – Plywood sheeting used as ground protection.



5.7 Single thickness of scaffold boards placed on top of driven scaffold frame to form a suspended walkway (Figure 7)

Figure 7 – Specification for scaffold ground protection.



5.8 Development can commence in accordance with the planning consent.

Method of constructing no dig surfaces close to trees

- 5.9** A cellular confinement system with a minimum depth of 100mm, or the minimum depth specified by an engineer to support cars, 4x4s and vans, will be utilised in this instance.
- 5.10** The appointed arboriculturalist will be invited to site to supervise the installation. Prepare the site by carefully hand raking any excessive organic matter and removing all debris and significant protrusions such as rocks. Use ground protection system if vehicular movements are unavoidable.
- 5.11** Ensure that the prepared surface is reasonably even and fill any significant depressions with 40/20 granular material to achieve an even surface profile. Do not roll or consolidate the area.
- 5.12** Install tanalised timber edging boards to the perimeter of the construction zone as appropriate to the total layer profile thickness. Avoid damage to tree roots when placing posts and pegs.
- 5.13** Install a geotextile layer across the site (a possible suggestion is Treetex T-300 supplied by Geosynthetics). The adjacent roles of geotextile membrane should overlap by 150mm. It may be necessary to lightly pin the geotextile membrane in place until the overlying layers are installed.
- 5.14** Place the Geogrid layer over the Geotextile Membrane layer and fix down using steel pins to hold flat. Overlap adjacent rolls by minimum 150mm. Avoid tree root damage and soil compaction by avoiding vehicular movements over the area.
- 5.15** Open out and lay the specified layer thickness of the Cellular Confinement System and pin in place between the edging boards. Pin the CCS in place using Steel Fixing Pins or similar and fully expanded position whilst the cells are being filled and to stop the structure from being pushed up by migrating aggregate during the filling process. Pin spacing will vary according to the site conditions but will generally be required at 1m - 2m centres on flat surfaces, mainly placed around the perimeter of the area and where adjacent sections of CCS about each, with less in the middle of the area. Drive the pins in so that they are just touching the top of the cells but do not compress the fabric. Avoid any obvious surface tree roots during the pinning process.
- 5.16** Fill the CCS, working toward the trees from the furthest point away and using the filled CCS as a platform. The Cells must be filled with clean, open graded angular aggregate, normally in the particle size range of 5mm - 45mm – not single sized or rounded aggregate. The surface can be rolled to settle the stone into the cells but a compaction plate (whacker) should not be used. Do not contaminate the filled cells with site debris, soil or mud.
- 5.17** Install the final binder course and permeable surface courses as per the manufacturer's instructions.

Figure 8 – Cellweb edging and transition details

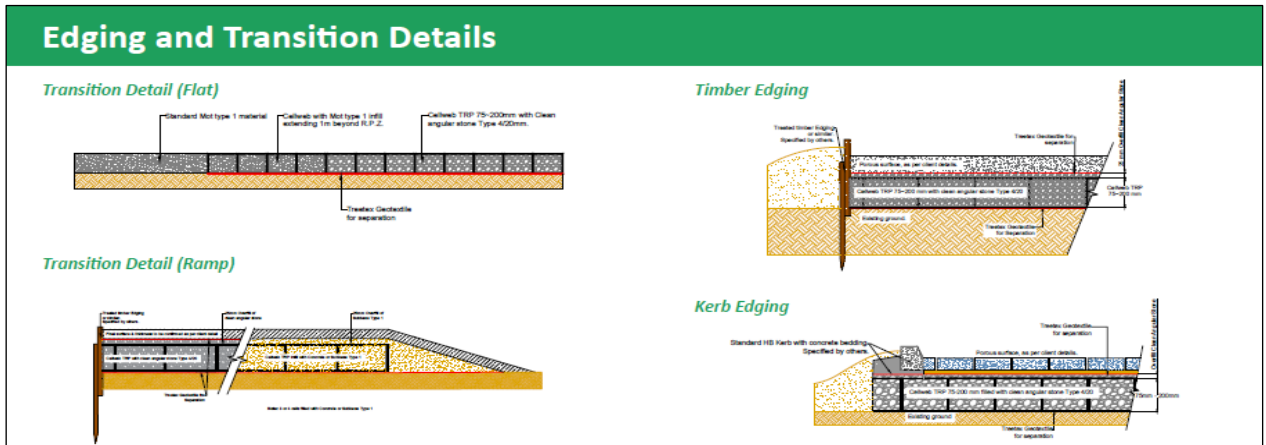

5.18 Following completion of all development the tree protection can be dismantled to allow landscaping works to take place.

Appendix 1 – British Standard 5837:2012 tree categorisation chart

TREES UNSUITABLE FOR RETENTION				
CATEGORY AND DEFINITIONS	CRITERIA			IDENTIFICATION ON PLAN
<p>Category U</p> <p>Those in such a condition that they cannot realistically be retained as living trees in the context of the current land use for longer than 10 years</p>	<ul style="list-style-type: none"> Trees that have a serious, irremediable, structural defect, such that their early loss is expected due to collapse, including those that will become unviable after removal of other category U trees (e.g. where, for whatever reason, the loss of companion shelter cannot be mitigated by pruning). Trees that are dead or are showing signs of significant, immediate, and irreversible overall decline. Trees infected with pathogens of significance to the health and/or safety of other trees nearby, or very low quality trees suppressing adjacent trees of better quality. <p><i>NOTE Category U trees can have existing or potential conservation value which it might be desirable to preserve; see 4.5 of BS5837:2012</i></p>			<p>RED █</p> <p>RGB 127.000.000</p>
TREES TO BE CONSIDERED FOR RETENTION				
CATEGORY AND DEFINITIONS	CRITERIA - SUBCATEGORIES			IDENTIFICATION ON PLAN
	1 Mainly arboricultural values	2 Mainly landscape values	3 Mainly cultural values, including conservation	
<p>Category A</p> <p>Trees of high quality</p> <p>with an estimated remaining life expectancy of at least 40 years</p>	<p>Trees that are particularly good examples of their species, especially if rare or unusual; or those that are essential components of groups or formal or semi-formal arboricultural features (e.g. the dominant and/or principal trees within an avenue).</p>	<p>Trees, groups or woodlands of particular visual importance as arboricultural and/or landscape features.</p>	<p>Trees, groups or woodlands of significant conservation, historical, commemorative or other value (e.g. veteran trees or wood-pasture)</p>	<p>LIGHT GREEN █</p> <p>RGB 000.255.000</p>
<p>Category B</p> <p>Trees of moderate quality</p> <p>with an estimated remaining life expectancy of at least 20 years</p>	<p>Trees that might be included in category A, but are downgraded because of impaired condition (e.g. presence of significant though remediable defects, including unsympathetic past management and storm damage), such that they are unlikely to be suitable for retention for beyond 40 years; or trees lacking the special quality necessary to merit the category A designation.</p>	<p>Trees present in numbers, usually growing as groups or woodlands, such that they attract a higher collective rating than they might as individuals; or trees occurring as collectives but situated so as to make little visual contribution to the wider locality.</p>	<p>Trees with material conservation or other cultural value</p>	<p>MID BLUE █</p> <p>RGB 000.000.255</p>
<p>Category C</p> <p>Trees of low quality</p> <p>with an estimated remaining life expectancy of at least 10 years, or young trees with a stem diameter below 150 mm</p>	<p>Unremarkable trees of very limited merit or such impaired condition that they do not qualify in higher categories.</p>	<p>Trees present in groups or woodlands, but without this conferring on them significantly greater collective landscape value; and/or trees offering low or only temporary/transient landscape benefits.</p>	<p>Trees with no material conservation or other cultural value.</p>	<p>GREY █</p> <p>RGB 091.091.091</p>

Appendix 2 - Tree survey schedule

agl:above ground level – c:circa – gl:ground level

Tree No.	Species	Height (m)	Trunk dia. at 1.5m	Canopy Spread	Crown Height (m)	Age Class	Physiological Condition	Structural Condition	Comments/ Recommendations	Useful Life Expect	BS5837 grade	Root Protection Area	
												Radius	RPA Area
T1	Apple (<i>Malus sp.</i>)	6m	350mm est	NE5m SE4m SW5.5m NW3.5m	2m	Mature	Good	Good	Off-site tree. Unremarkable tree.	10+	C	4.2m	55.4m ²
T2	Common Holly (<i>Ilex aquifolium</i>)	8m	250mm est	NE3m SE3m SW2.5m NW3m	0m	Semi mature	Good	Good	Off-site tree. Unremarkable tree. Works required for development: Reduce south-eastern crown by up to 1m to leave final radial lateral spread of c2m.	10+	C	3.0m	28.3m ²
T3	Common Yew (<i>Taxus baccata</i>)	10m	225mm 275mm est	NE4m SE2.5m SW5.5m NW3m	3m	Semi mature	Fair	Fair	Off-site tree. Unremarkable tree. Medium sized deadwood 25mm to 100mm. Fair vitality demonstrated by browning of needles and suppression of foliage by Ivy within upper crown.	10+	C	4.3m	57.1m ²
T4	Common Yew (<i>Taxus baccata</i>)	8m	230mm	NE3.5m SE4.5m SW4.5m NW2m	1.5m	Semi mature	Good	Good	Unremarkable tree.	10+	C	2.8m	23.9m ²

Tree No.	Species	Height (m)	Trunk dia. at 1.5m	Canopy Spread	Crown Height (m)	Age Class	Physiological Condition	Structural Condition	Comments/ Recommendations	Useful Life Expect	BS5837 grade	Root Protection Area	
												Radius	RPA Area
T5	Common Oak (<i>Quercus robur</i>)	14m	800mm est	NE7.5m SE4.5m SW7.5m NW10m	N3m E3m S2m W3m	Mature	Good	Fair	Crown has been previously reduced. Main stem leans in northerly direction by c40 degrees, straightening to near vertical at 2m agl.	20+	B	9.6m	289.5m ²
T6	Douglas Fir (<i>Pseudotsuga menziesii</i>)	14m	450mm est	NE7m SE5m SW5m NW5m	5m	Early mature	Good	Good	Off-site tree. Unremarkable tree.	10+	C	5.4m	91.6m ²
T7	Magnolia (<i>Magnolia soulangiana</i>)	6m	125mm 100mm 75mm est	NE4m SE1m SW3m NW1.5m	1.5m	Young	Good	Fair	Off-site tree. Unremarkable tree. Suppressed as overtopped by adjacent tree.	10+	C	2.1m	14.1m ²

Appendix 3 – Tree Constraints Plan – RMT1065 – TCP

Tree constraints plan (TCP) showing retained trees, tree numbers, root protection areas (magenta circles/polygons) and canopy spreads (green lines). The plan has been provided separately as a PDF at a scale of 1: 200 @ A2.

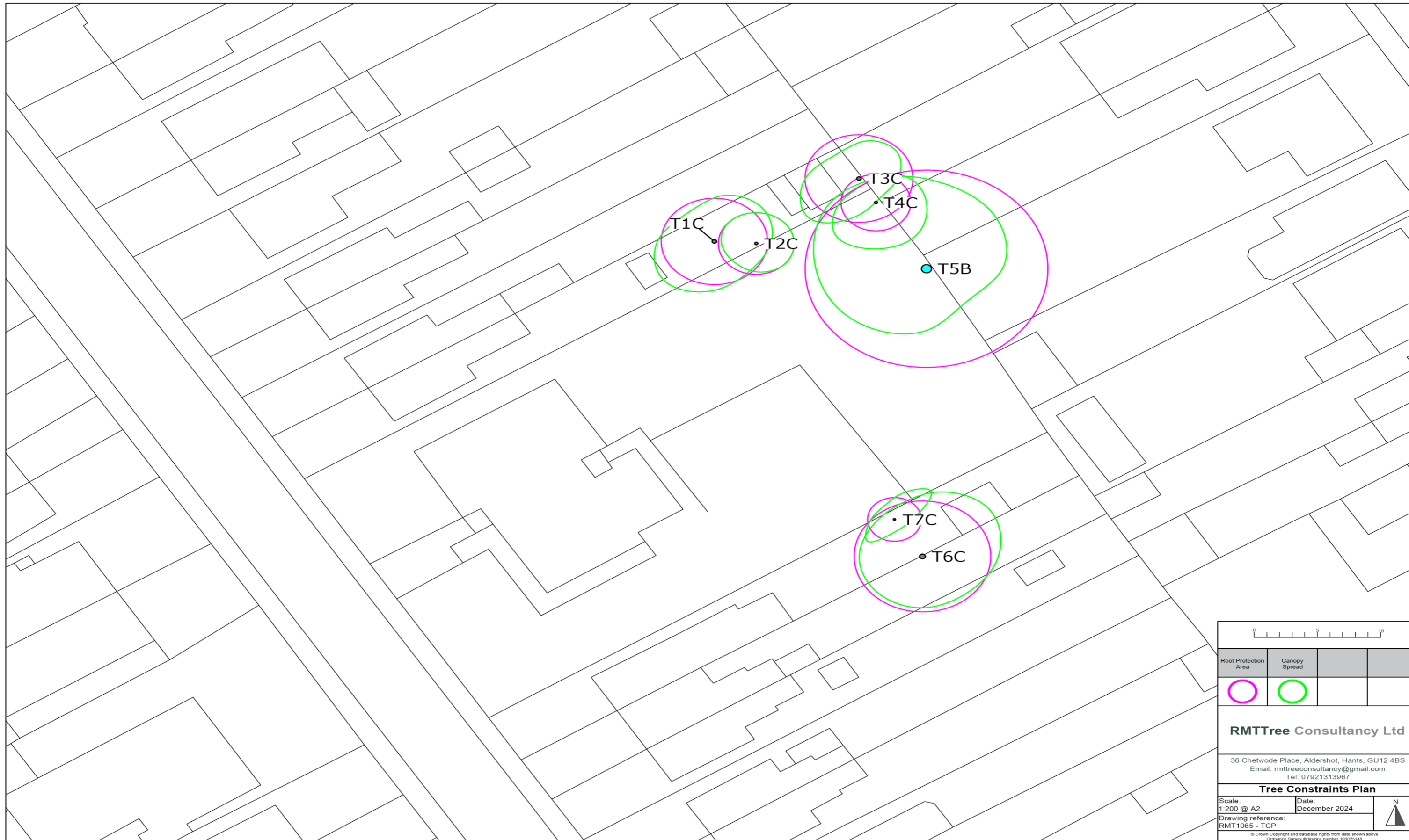

Appendix 4 – Tree Protection Plan – RMT1065 – TPP

Tree protection plan (TPP) showing retained trees, tree numbers, root protection areas (magenta circles/polygons) and canopy spreads (green lines). The location of protective fencing is shown as blue lines, ground protection as orange hatching and no dig surfacing as red hatching and sensitive demolition as light blue hatching. The plan has been provided separately as a PDF at a scale of 1: 200 @ A2.

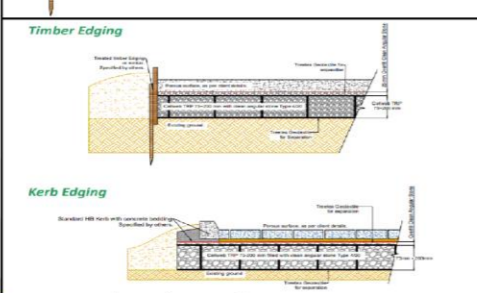
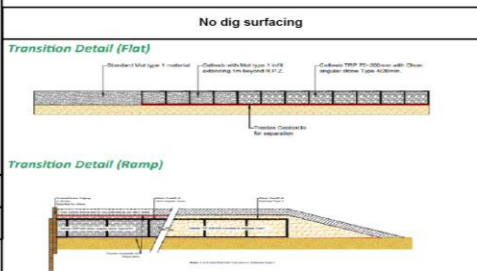
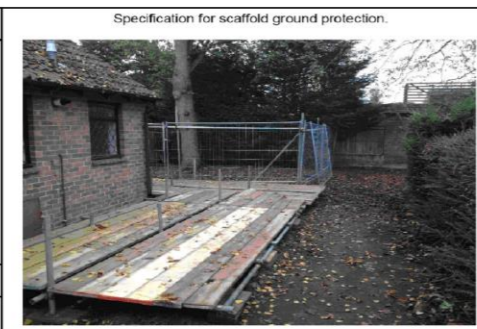
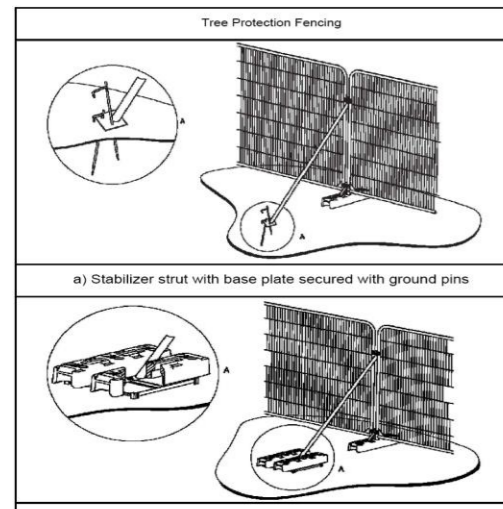
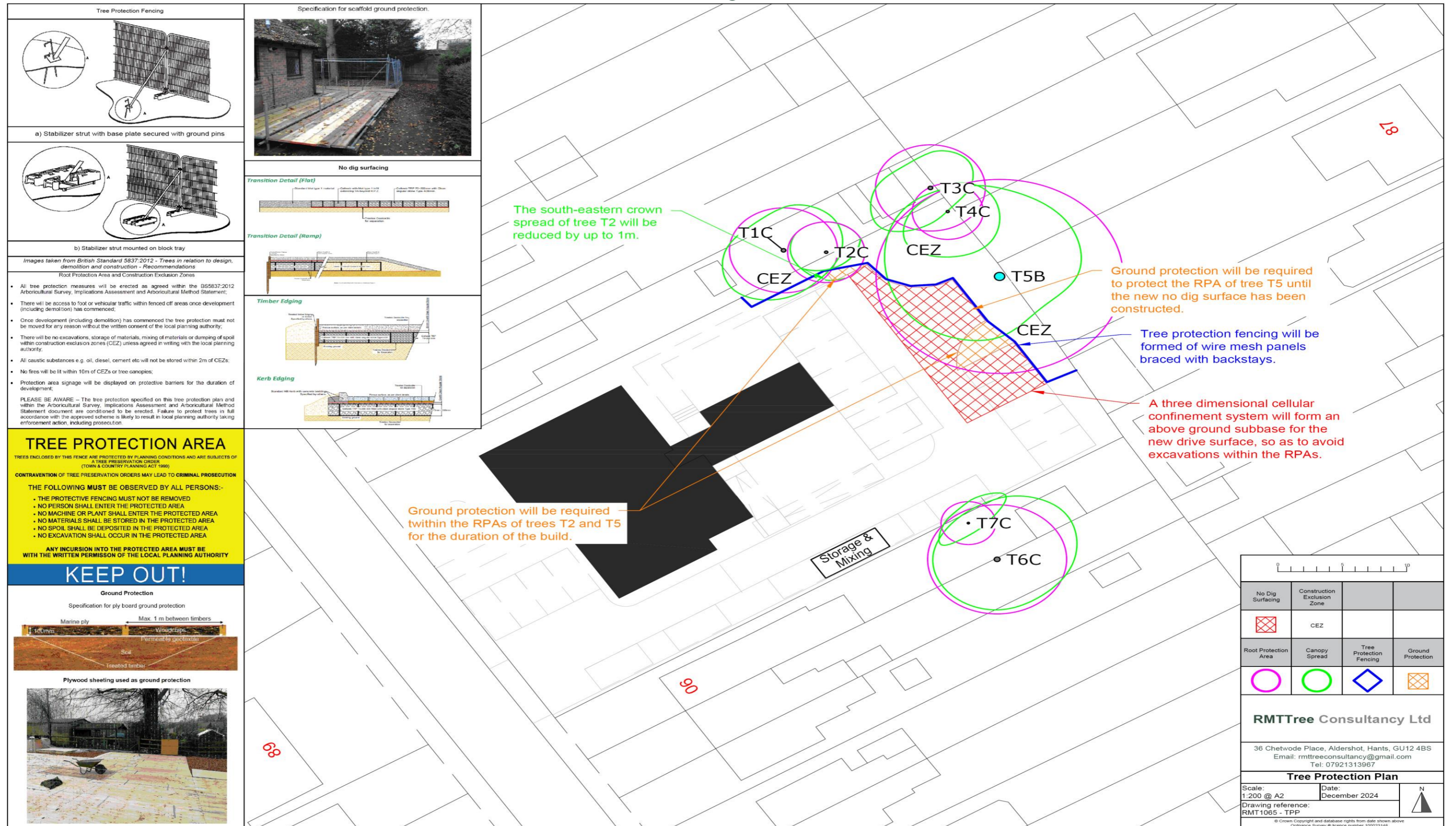

Images taken from British Standard BS37:2012 - Trees in relation to design, demolition and construction - Recommendations

Root Protection Area and Construction Exclusion Zones

- All tree protection measures will be erected as agreed within the BS5837:2012 Arboricultural Survey, Implications Assessment and Arboricultural Method Statement.
- There will be access to foot or vehicular traffic within fenced off areas once development (including demolition) has commenced.
- Once development (including demolition) has commenced the tree protection must not be moved for any reason without the written consent of the local planning authority.
- There will be no excavations, storage of materials, mixing of materials or dumping of spoil within construction exclusion zones (CEZ) unless agreed in writing with the local planning authority.
- All caustic substances e.g. oil, diesel, cement etc will not be stored within 2m of CEZs.
- No fires will be lit within 10m of CEZs or tree canopies.
- Protection area signage will be displayed on protective barriers for the duration of development.

PLEASE BE AWARE – The tree protection specified on this tree protection plan and within the Arboricultural Survey, Implications Assessment and Arboricultural Method Statement document are conditioned to be erected. Failure to protect trees in full accordance with the approved scheme is likely to result in local planning authority taking enforcement action, including prosecution.

TREE PROTECTION AREA

TREES ENCLOSED BY THIS FENCE ARE PROTECTED BY PLANNING CONDITIONS AND ARE SUBJECTS OF A TREE PRESERVATION ORDER (TOWN & COUNTRY PLANNING ACT 1990)

CONTRAVENTION OF TREE PRESERVATION ORDERS MAY LEAD TO CRIMINAL PROSECUTION

THE FOLLOWING MUST BE OBSERVED BY ALL PERSONS:-

- THE PROTECTIVE FENCING MUST NOT BE REMOVED
- NO PERSON SHALL ENTER THE PROTECTED AREA
- NO MACHINE OR PLANT SHALL ENTER THE PROTECTED AREA
- NO MATERIALS SHALL BE STORED IN THE PROTECTED AREA
- NO SPOIL SHALL BE DEPOSITED IN THE PROTECTED AREA
- NO EXCAVATION SHALL OCCUR IN THE PROTECTED AREA

ANY INCURSION INTO THE PROTECTED AREA MUST BE WITH THE WRITTEN PERMISSION OF THE LOCAL PLANNING AUTHORITY

KEEP OUT!

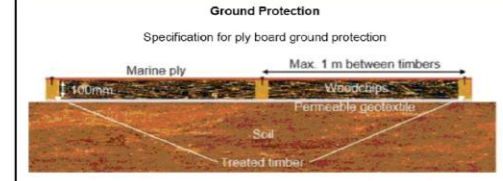

0 10 20 30 40 50			
No Dig Surfacing	Construction Exclusion Zone		
	CEZ		
Root Protection Area	Canopy Spread	Tree Protection Fencing	Ground Protection
RMTTree Consultancy Ltd			
36 Chetwode Place, Aldershot, Hants, GU12 4BS Email: rmttreeconsultancy@gmail.com Tel: 07921313967			
Tree Protection Plan			
Scale: 1:200 @ A2	Date: December 2024		
Drawing reference: RMT1065 - TPP			
<small>© Crown Copyright and database rights from data shown above Ordnance Survey © licence number 100023148</small>			

Appendix 5 – Arboricultural site supervision schedule

Activity	Supervision Required
Pre-commencement meeting between the local authority arboricultural officer, the appointed arboriculturalist and the appointed building contractor.	✓
During the setting out of no dig surfacing within the RPA of T5.	✓
At any time that there are conflict issues with the agreed tree protection.	✓

Following every visit the appointed arboriculturalist will fill out the site monitoring form which is shown at **Appendix 6** and this will be forwarded to the LPA.

Appendix 6 – Site monitoring form

RMTTree Consultancy Ltd 			
Site monitoring form			
Date of visit		Site	
Consultant in attendance			
Observations/status of tree protection/comments:			
Recommendations (if necessary):			
Date of next visit		Signature	

Cellweb® TRP Installation Guide



Step 1: Prepare Surface



Step 2: Lay out Treetex™



Step 3: Lay out Cellweb® TRP

- Cellweb® TRP is a NO DIG tree root protection measure and it is recommended that no excavation be performed without prior approval and guidance from the Local Authority Arboricultural Officer.
- Soil compaction from vehicles, machinery and materials is to be strictly prohibited during construction within Root Protection Areas (RPAs).
- Approval must be obtained from the Local Authority that the design and the method of construction is acceptable.
- Further information is available from the following two documents;
 - British Standard BS5837: 'Trees in Relation to Design, Demolition and Construction' (2012).
 - Arboricultural Advisory and Information Service: Practice note 12 – 'Through the Trees to Development' (APN12).

Installation Method

1. Prepare the Surface

- Remove the surface vegetation using appropriate hand held tools or herbicide (see Note 1).
- Remove any surface rocks, debris and organic material.
- Create a level surface by filling any hollows with clean angular stone or sharp sand.
- Do not level off high spots or compact the soil through rolling.

2. Lay out the Treetex™ Non-Woven Geotextile

- Lay out the Treetex™ over the prepared area, overlaying the edges of the required area by 300mm.
- Overlap any joins by 300mm minimum or more, depending on soil structure (see Note 2).

3. Lay out the Cellweb® TRP Cellular Confinement System

- Lay out the collapsed Cellweb® TRP on-top of the Treetex™.
- Place one of the supplied J pins into the centre cell at the end of the panel and secure into the ground.

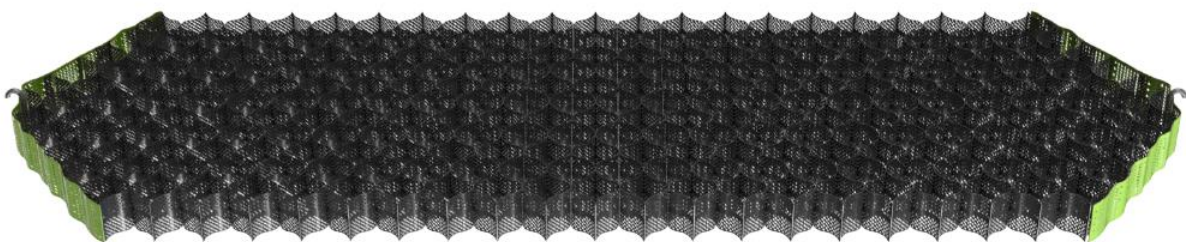

Cellweb® TRP - Installation Guide



Step 3: Pinning Cellweb® TRP



Step 3: Stapling Cellweb® TRP

- Pull out the Cellweb® TRP to its full 8.1m length and secure its length with another J pin.

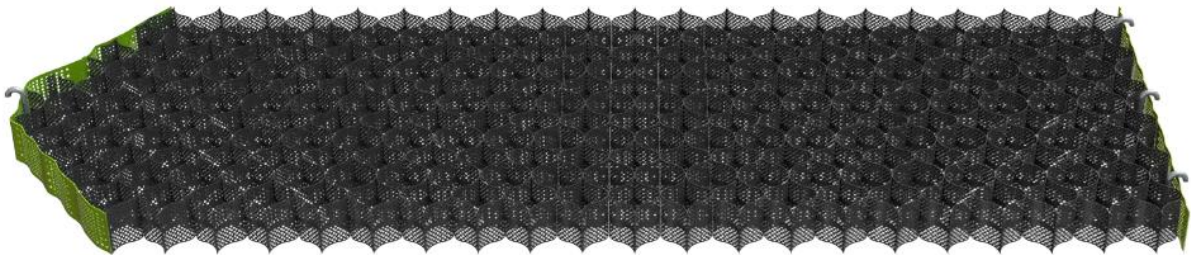

- Now measure its width to 2.56m and secure in each of the corners with the J pins.
- Use 10 pins per panel to create a panel measuring 8.1m x 2.56m.

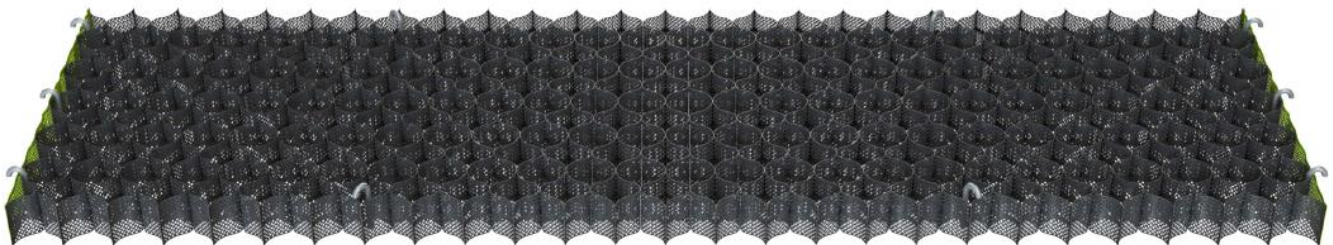

- This will produce a cell size of 259mm x 224mm which is the required cell diameter. Each cell must be fully extended and under tension.
- Staple adjacent panels together at each cell (see Note 3).
- If a curved path or shape is required, this should be cut when the Cellweb® TRP panel is pinned out to 8.1 x 2.56m, ensuring complete cells remain. Do not try to curve or bend the Cellweb® TRP panels into place.
- All cells must be fully opened to the required diameter.

Cellweb® TRP - Installation Guide



Step 4: Clean Angular Stone



Step 5: Edge Restraints



Step 6: Surface Options

4. Infill the Clean Angular Stone

- The infill material must be a clean angular stone, Type 4/20mm or Type 20/40mm (see Note 4).
- Do not use M.O.T type 1 or crushed stone with fines for tree root protection.
- Infill the Cellweb® TRP cells with the clean angular stone, working towards the tree and using the infilled panels as a platform.
- Minimum 25mm overfill of clean angular stone when used in conjunction with a hard surface.
- No compaction is required of the infill. Do not use a whacker plate or other means of compaction.
- Encourage settlement of the stone with the use of a light roller or with 2-3 passes of the construction plant used for installation.
- If the clean angular stone is being used as the final surface; regular maintenance will be required to ensure a minimum overfill of 50mm.

5. Edge restraints

- Excavations for kerbs and edgings should be avoided within the RPAs.
- Where edging is required for footpath and light structures, a peg and treated timber board edging is acceptable
- Other options include wooden sleepers, kerb edging constructed on-top of the Cellweb® TRP system, plastic and metal edging etc.

6. Surface options

- All surfaces in Root Protection Areas must be porous. Surfaces can include block paving, asphalt, loose gravel, grass and gravel retention systems (e.g Golpla), resin bound gravel, concrete etc.

NOTES

1. **Herbicide:** According to BS5837:2012 "The use of herbicides in the vicinity of existing trees should be appropriate for the type of vegetation to be killed, and all instructions, warnings and other relevant information from the manufacturers should be strictly observed and followed. Care should be taken to avoid any damaging effects upon existing plants and trees to be retained, species to be introduced, and existing sensitive habitats, particularly those associated with aquatic or drainage features."
2. **Geotextile:** We recommend the installation of a Treetex™ under the Cellweb® TRP, or under the sub-base, if installed. The overlapping between adjacent rolls of Geotextile should be: CBR > 3%: 300mm minimum, CBR between 1% and 3%: 500mm minimum. CBR ≤ 1%: 750mm minimum.
3. **Staples:** Number of staples per join: 200mm: 5 staples. 150mm: 4 staples. 100mm: 3 staples. 75mm: 3 staples.
4. **Granular Fill:** Open graded sub-base, clean angular stone Type 4/20 or Type 20/40. Please refer to BS7533-13:2009 and to the Design Manual for Roads and Bridges (DMRB), Volume 4 Geotechnics and Drainage, Section 1 Earthworks, HA44/91, Volume 7 – IAN 73/06 Design Guidance for road pavement foundations and Manual of Contract Documents for Highway Works (MCHW), Volume 1 Specification for Highway Works for the construction and maintenance of the fill material.

This information corresponds to our current knowledge on the subject. It is offered solely to provide possible suggestions for your own experimentation. It is not intended, however, to substitute for any testing you may need to conduct to determine for yourself the suitability of our products for your particular purposes. This information may be subject to revision as new knowledge becomes available. Since we cannot anticipate all variations in actual end use conditions, Geosynthetics Limited makes no warranties and assumes no liabilities in connection with this information. Nothing in this publication is to be considered as a licence to operate under or a recommendation to infringe any patent right.

DR: 81/V4/13.05.16 (Page 3 of 3)



Appendix 8 – Qualifications and experience

Robert Toll has been working with trees since 2004 when he completed his studies.

In 2000 he began his studies at Riseholme College, Lincoln where achieved a pass with merit in Forestry at National Diploma level. In 2002 he attended Moulton College in Northampton where he gained a Level Five Higher National Diploma in Urban Forestry with merit.

In 2004 Robert began work as a temporary tree inspector at Northampton Borough Council, undertaking inspections of trees in response to enquiries from the public. After 4 months Robert took up a permanent tree inspector role at Coventry City Council which predominantly involved undertaking safety inspections of trees on school sites.

In 2006 Robert moved to Warwick District Council to take up a temporary post of Tree Protection Officer which involved reviewing old area tree preservation orders and identifying those trees which were considered worthy of protection under new specific orders. He also streamlined the council procedure for making new tree preservation orders, cutting the time from making to serving from up to 2 weeks to within 2 hours.

In 2008 Robert moved to Hart District Council, Hampshire to take up the role of Tree Officer within the planning department. This role included determining works trees applications, commenting on planning proposals, liaising with the public and providing arboricultural advice to other departments within the Council.

Between 2014 and 2016 Robert took up the role of Tree Officer at Elmbridge Borough Council, Surrey, once again carrying out tasks such as determining works trees applications, commenting on planning proposals and liaising with the public. While at Elmbridge Borough Council he passed the Arboricultural Association's Professional Tree Inspection course.

Robert is a professional member of the Arboricultural Association.